

THE CARPET AND RUG INSTITUTE

COMMERCIAL CARPET

STANDARD  
For INSTALLATION of  
COMMERCIAL CARPET  
CRI 104 – Sept 2015

Copyright © 2015 by the Carpet and Rug Institute, Inc.  
Originally published 1982 with revisions issued 1984,  
1986, 1988, 1991, 1992, 1993, 1994, 1996, 2002 and 2015.  
All rights reserved.

### **Disclaimer**

The Carpet and Rug Institute (CRI) is the national trade association of carpet and rug manufacturers and suppliers to the industry. The expertise of CRI's membership comes together to provide unbiased technical, educational, and scientific information about carpet and rugs.

The Carpet and Rug Institute assumes no responsibility and accepts no liability for the application of the principles or techniques contained in this standard. Specifying authorities are responsible for reviewing applicable federal, state and local statutes, ordinances, and regulations including mandatory requirements contained in the Occupational Safety and Health Administration (OSHA) Hazard Communication Regulation.

## Contents

FOREWORD.....	6
ACKNOWLEDGEMENTS.....	7
GENERAL REQUIREMENTS.....	8
1.0    Applicable Documents and References .....	8
1.1    Carpet and Rug Institute References: .....	8
1.2    Most recent ASTM Standards: .....	8
2.0    Terminology.....	8
3.0    Tools and Materials.....	8
4.0    Storage and Handling.....	8
4.1    Storage.....	8
4.2    Handling .....	8
5.0    Planning .....	9
5.1    Shop Drawings .....	9
5.2    Planning for Seams.....	10
5.3    Transitions to Other Surfaces .....	10
5.4    Carpet Over Expansion Joints .....	10
5.5    Pile Direction.....	11
5.6    Pattern Matching .....	11
6.0    Testing.....	11
6.1    Moisture Vapor Emission Rate (MVER) Testing.....	12
6.2    Relative Humidity (RH) Testing .....	12
6.3    Testing for Alkalinity .....	12
7.0    Site Conditions.....	12
7.1    Substrate Conditions.....	12
7.2    Ambient Temperature and Humidity Suitable Substrates .....	13
7.3    Ventilation.....	13
8.0    Substrate Preparation .....	13
8.1    Concrete.....	14
8.2    Wood .....	14
8.3    Metal.....	15
8.4    Raised Access Flooring.....	15
8.5    Resilient.....	15
8.6    Carpet over Carpet.....	15
8.7    Radiant Heat Floors.....	15
8.8    Terrazzo, Ceramic, Marble, Slate and Other Nonporous Surfaces .....	16

8.9	Asphalt.....	16
8.10	Painted Surfaces .....	16
8.11	Primers.....	16
8.12	Chemical Adhesive Removers and Abatement Chemicals .....	16
8.13	Sweeping Compounds .....	17
9.0	Product Acclimation .....	17
Carpet Tile	.....	17
10.0	Carpet Tile Installation.....	17
10.1	Layout.....	17
10.2	Adhesive Application .....	17
10.3	Tile Joints .....	18
10.4	Rolling.....	18
10.5	Pre-applied Adhesive Systems (“peel-and-stick”) .....	18
11.0	Post Installation .....	18
Broadloom Carpet.....	.....	18
12.0	Carpet Seaming .....	18
12.1	Trimming.....	18
12.2	Sealing Edges/Seams.....	19
12.3	Seaming Methods .....	19
12.4	Proper Seam Characteristics.....	20
13.0	Direct Glue Down .....	21
13.1	Layout.....	21
13.2	Floor Adhesive Application .....	21
13.3	Alternative Adhesive Systems.....	22
13.4	Seam Sealing .....	22
13.5	Rolling.....	22
13.6	Finishing at Wall Line.....	22
13.7	Post Installation .....	22
14.0	Double Glue Down.....	23
14.1	Cushion Layout .....	23
14.2	Layout.....	23
14.3	Adhesives and Trowel Notch Sizes.....	23
14.4	Cushion to Substrate Installation.....	24
14.5	Carpet to Cushion Installation.....	24
14.6	Edge Sealing.....	24
14.7	Seam Cutting .....	24

14.8	Seaming.....	24
14.9	Rolling.....	24
14.10	Post Installation.....	25
15.0	Attached Cushion Install.....	25
15.1	Carpet Layout.....	25
15.2	Floor-Applied Adhesive Installations.....	25
15.3	Installation Procedures.....	25
15.4	Pre-applied Adhesive Systems (“peel-and-stick”).....	26
16.0	Stretch-in Installation.....	26
16.1	Tack-strip.....	26
16.2	Separate Cushion Selection.....	27
16.3	Seaming.....	27
16.4	Power Stretching.....	27
16.5	Amount of Stretch.....	29
16.6	Finishing at Wall.....	30
16.7	Transition Molding.....	30
17.0	Carpet on Stairs.....	30
17.1	Preparation.....	30
17.2	Stretch-in Installation.....	30
17.3	Glue-down Installation.....	30
17.4	Carpet Direction.....	31
18.0	Patterned Carpet Installations.....	31
18.1	Uninstalled Patterned Carpet.....	31
18.2	Manufacturing Tolerances.....	31
18.3	Seaming Diagram.....	31
18.4	Pattern Sequence/Roll Sequence.....	32
18.5	Pattern Adjustment.....	32
18.6	Pattern Alignment.....	32
	Appendices.....	33
	Definition of Terms.....	33
	Table I – Tools & Materials.....	37
	Table II – Trowel Size Minimum Guidelines.....	39
	Table III – Tack Strip.....	40
	Table IV – Adhesive Types / Definitions.....	41
	Table V – Dew Point.....	42
	CRI Member Contact Information.....	43

## **FOREWORD**

Products have unique characteristics and each installation project should be carefully evaluated to determine proper application of this standard. In circumstances not addressed in this document, contact the product manufacturer for specific guidance. The CRI requires that the services of professionally trained and qualified floor covering installers be obtained for all Commercial carpet installations.

This minimum standard requirement for installation of carpet is based upon reliable principles and procedures developed through practical experience, research, and information obtained from manufacturers, retailers, installers, end users, testing laboratories, and others who have specialized expertise. For more detailed information, instructions and training, please contact the specific manufacturer.

Failure to follow this minimum standard may result in an installation related failure; however it cannot be the basis for rejecting a claim relating to a manufacturing defect.

For the most current version of the CRI 104, please visit the Carpet and Rug Institute at [www.carpet-rug.org](http://www.carpet-rug.org).

## **ACKNOWLEDGEMENTS**

This Standard was prepared under the direction of the Installation Subcommittee of the Carpet and Rug Institute and in cooperation with numerous experts in the carpet installation and related fields.

### **CRI INSTALLATION TASK GROUP CHAIRMAN**

Woody Belflower - Shaw Industries Group, Inc.

### **CRI INSTALLATION TASK GROUP PROJECT COORDINATOR**

Pat Jennings, The Carpet and Rug Institute, Inc.

### **CRI INSTALLATION TASK GROUP MEMBERS:**

Mark Berndt – Bentley Mills Inc.

Eric Boender - Starnet Worldwide Commercial Flooring Partnership

Scott Bradley – Mohawk Industries

Mike Del Vacchio – Milliken & Company

Jimmy Garrett – Interface Americas

John Geier – W.F. Taylor Co., Inc.

Grace Gilbreath – XL Brands

Charlie Nielsen – MAPEI Corporation/APAC

Richard Pickens – Engineered Floors LLC

Scott Sales – XL Brands

Andrew S. Smith – Mohawk Industries

David Wardlaw – Tai Ping Carpets Americas, Inc.

### **CRI INSTALLATION TASK GROUP CONTRIBUTORS:**

Dan Channell - Shaw Industries Group, Inc.

Brian Howard - Shaw Industries Group, Inc.

## GENERAL REQUIREMENTS

### **1.0 Applicable Documents and References**

#### **1.1 Carpet and Rug Institute References:**

- [The Carpet Primer](#) \*
- [Carpet Maintenance and Troubleshooting](#)\*

#### **1.2 Most recent ASTM Standards:**

- ASTM F-710 – Standard Practice for Preparing Concrete to Receive Resilient Flooring
- ASTM F-1869 – Test Method for Measuring Moisture Vapor Emission Rate of Concrete Subfloor Using Calcium Chloride
- ASTM F-2170 – In-situ Relative Humidity Testing

### **2.0 Terminology**

For terms and definitions used in this standard, refer to the [Definitions of Terms](#) section in the Appendix of this document.

### **3.0 Tools and Materials**

Carpet installation requires using tools and materials referenced in this standard. Refer to the [Tools and Materials](#) tables in the Appendix of this document.

### **4.0 Storage and Handling**

#### **4.1 Storage**

Store carpet and related materials in a climate-controlled, dry space. Protect carpet from soil, dust, moisture and other contaminants and store on a flat surface. Stacking heavy objects on top of carpet rolls is prohibited. Double stacking pallets of carpet tile should be avoided unless approved by the manufacturer.

#### **4.2 Handling**

Transport carpet in a manner that prevents damage and distortion. Bending or folding individual carpet rolls or cuts from rolls are not recommended. When bending or folding is unavoidable for delivery purposes, the carpet is required to be unrolled and allowed to lie flat immediately upon arrival at the installation site.



**NOTE: Failure to observe the preceding requirements may result in the following:**

- **Contamination from soil, grease and/or oil**
- **Delamination**
- **Dimensional changes**
- **Permanent indentation**
- **Development of wrinkles and bubbles**
- **Pile reversal**
- **Pile crushing**
- **Creases**
- **Pattern distortion**

## **5.0 Planning**

All facets of the installation are to be coordinated. A scale drawing of the area to be installed is required to determine type of carpet, carpet quantities, quantity per dye lot, installation method, cushions, adhesives, transition moldings, wall base types and other accessories, and to identify the proper location of seams.

On new construction, provide architectural drawings that define the entire installation area with space names or numbers and a finish schedule of flooring style, patterns, colors and installation methods. On existing structures, provide new measurements and shop drawings.

Consideration should be given to carpet and adhesive conditioning, material delivery considerations, material reclamations and other trades' schedules.

### **5.1 Shop Drawings**

The carpet shop drawing is required to contain the following information:

- Name of the job, owner and installation company. On new construction the name of the general contractor and architectural firm are required.
- Building address
- Date of drawing
- Scale
- Floor number and location in building
- Compass direction on each sheet
- Drawing for each area to be carpeted (color coding is preferable)
- Construction of substrate for each area
- Required floor preparation, materials and quantities.
- Type of installation for each area
- Exact notations where dye lot changes occur

- Proper quantities of installation materials needed for each area including but not limited to:
  - carpet needed for each area, including roll length requirements (allow a minimum of 3 inches (75 mm) longer than the area measurement), length of pattern repeat, manufacturer roll or pallet sequence (where applicable)
  - specified adhesives per manufacturer instructions
- Excess material in each area and how it is to be used
- Seam layout of each area
- Carpet pile or pattern direction for each area
- Name of manufacturer, style, backing system and color of carpet for each area
- Large scale drawings showing treatment of step areas or other detail work
- Location and type of expansion joints and edge transitions.
- Type of wall base in each area.

## **5.2 Planning for Seams**

Keep seams to a minimum. When possible, position seams so that:

- Seams run the length of the area.
- Main traffic flow runs along rather than across the seam.
- Natural light does not strike across the seam.
- Seams are away from areas subject to pivoting traffic.
- Seams are not perpendicular to doorway openings.

## **5.3 Transitions to Other Surfaces**

Where carpet transitions to other floor coverings, the carpet edges are required to be protected or covered with appropriate transition moldings. The edge of the hard surface flooring should not exceed a maximum of 1/16" higher than the total carpet thickness where no transition molding exists. For broadloom where no transition molding is used, apply a minimum of 1/8" bead of seam sealer to the edge of the carpet along the entire transition.

Wall base - when vinyl or rubber wall base is used in a direct glue or double glue carpet installation, cove base or base-with-toe is recommended.

## **5.4 Carpet Over Expansion Joints**

Do not install carpet over expansion joints (see [definition](#)). Expansion joints allow separate substrate surfaces to expand and contract independently. In addition, do not install on any area of a floor that does not provide a stable and mechanically sound surface. This does not include cut or saw joints within a section of the floor. Non-stable/unsound substrate joint conditions are required to be addressed in strict accordance with the appropriate architectural drawing. If no expansion joint

device is specified on the drawing, the building owner, owner's representative, or other responsible party is required to be made aware that failure to address expansion joints will potentially result in installation failure, damage to the carpet and/or safety concerns.

### 5.5 Pile Direction

Where two or more pieces of the same broadloom carpet are adjacent, the pile direction is required to be the same unless otherwise specified. Uniform pile direction is not required with dissimilar carpet.

**NOTE: Ideally, install carpet with the pile lay toward the entrance; but other factors, such as pattern, aesthetics and economic use of material may be considered.**

### 5.6 Pattern Matching

Refer to [Section 18](#). Consult the manufacturer for specific installation requirements and possible warranty conditions.

## 6.0 Testing

Refer to the manufacturer's written instructions for guidelines regarding allowable moisture and pH limits for their products. The Moisture Vapor Emission Rate, Relative Humidity & Alkalinity testing must be performed to give an accurate assessment of the concrete condition and the test results/data of each test shall be within acceptable limits.

Before direct glue-down, double-glue down, free floating carpet tile systems and some stretch-in installations, the owner or general contractor, or their designated testing agent, is required to submit to the flooring contractor a written report on the moisture and alkalinity conditions of the concrete substrates.

**Proper testing is essential for a successful installation and any deviation from these industry accepted test methods often results in an installation failure and may void manufacturers' warranties.**

**NOTE: It is recommended that qualified independent third-party testing agencies be used for determining moisture and alkalinity conditions of a concrete slab. Testing by an independent third party specialist to determine installation suitability is a prudent and necessary safeguard for general contractors, owners, architects, flooring product providers and installation contractors to reduce the risk of concrete slab moisture related flooring problems. As a minimum, testing agencies or individuals are required to demonstrate verifiable experience in concrete moisture testing or be certified by a recognized organization.**

## 6.1 Moisture Vapor Emission Rate (MVER) Testing

MVER tests must be conducted in accordance with the current version of ASTM F 1869, not to exceed manufacturer's requirements (ASTM F1869 - Standard Test Method for Measuring Vapor Emission Rate of Concrete Subfloor Using Anhydrous Calcium Chloride).

## 6.2 Relative Humidity (RH) Testing

Testing for internal relative humidity of concrete slabs must be conducted in accordance with the current version of ASTM F-2170, not to exceed manufacturer's requirements (ASTM F2170 - Standard Test Method for Determining Relative Humidity in Concrete Floor Slabs Using In-Situ Probes).

## 6.3 Testing for Alkalinity

Testing the pH at the surface of a concrete slab must be conducted in accordance with the current version of ASTM F710, not to exceed manufacturer's requirements (ASTM F710 - Standard Practice for Preparing Concrete Floors to Receive Resilient Flooring).

**NOTE: Preparing the surface of a concrete slab for pH testing can be problematical. Make sure the concrete surface is adequately cleaned of adhesives, curing compounds etc. When pH readings are less than 7, it may be an indication of a residue remaining on the concrete surface. Also use care not to over clean the surface of the concrete, consequently removing the (usually) thin layer of carbonation. This can result in pH readings >12.**

## 7.0 Site Conditions

### 7.1 Substrate Conditions

The owner or general contractor is responsible for providing an acceptable substrate for the specified installation. Proper site conditions as outlined in this section are essential for a successful installation and any deviation often results in an installation failure and may void manufacturers' warranties.

**NOTE: Installing carpet before other trades have completed their work may result in problems with: overall appearance, visible damage, soiling, adhesive failure, delamination and dimensional stability. These conditions may not be immediately evident. Refer to [Section 13.7](#).**

## 7.2 Ambient Temperature and Humidity Suitable Substrates

The installation is not to begin until the HVAC system is operational and the following conditions are maintained for at least 48 hours before, during and 72 hours after completion. The carpet is to be installed when the indoor temperature is 65-95°F (18-35°C) with a maximum relative humidity of 65%. The substrate surface temperature should not be less than 65°F (18°C) at time of installation. Do not allow the temperature of indoor carpeted areas to fall below 50° F (10° C), regardless of the age of the installation. If these conditions are not attainable, contact the flooring manufacturer for applications to warranty.

**NOTE: If the above conditions are not met, installations may be susceptible to moisture related failures including but not limited to dew point condensation.**

## 7.3 Ventilation

During installation, maintain air circulation by operating the HVAC system at full capacity.

**NOTE: For acceptable indoor air quality, fresh air ventilation in commercial spaces is recommended to conform to current guidelines specified in ASHRAE Standard 62 published by the American Society of Heating, Refrigerating and Air Conditioning Engineers ([www.ashrae.org](http://www.ashrae.org)). Failure to comply could cause negative ramifications to the installation and the indoor air quality.**

## 8.0 Substrate Preparation

Carpet is required to be installed over properly prepared substrates that are suitable for the specific product and installation method selected. All cracks, holes and flooring irregularities are required to be repaired to ensure a flat, smooth substrate, prevent accelerated wear and telegraphing substrate irregularities. Substrates are required to be structurally sound and free of foreign substances that may compromise the carpet or its installation. Patching compounds are required to be suitable for the intended application. Select polymer-fortified patching compounds according to the carpet manufacturer's instructions. (Refer to current version of ASTM E1155).

**NOTE: Patched areas may be porous and highly alkaline, which will prevent adequate adhesive bond. For best results, prime patched areas. Consult patch manufacturer for primer recommendations and compatibility with adhesives.**

## 8.1 Concrete

Concrete must be cured, clean, dried and tested in accordance to [Section 6.0](#). If the carpet is to be installed using an adhesive, the concrete should be free of dirt, grease, oil, curing or parting agents, and other contaminants, including sealers, that may interfere with the bonding of adhesive.

**NOTE: It is not recommended to chemically treat (abate) substrates. These chemicals are difficult to completely remove and will adversely affect new adhesive and carpet. Contact your manufacturer for specific information.**

Whenever a powdery or porous surface is encountered, a primer/sealer compatible with the adhesive should be used to provide a suitable surface for the glue-down installation. Patching of cracks and depressions shall be made with appropriate and compatible latex or polymer fortified patching compound. Do not exceed manufacturer's recommendations for patch thickness. Large patched areas must be primed (Refer to [Section 8.11](#)).

**NOTE: Any concrete floor, even when adequately cured and dry, can allow moisture vapor to pass through to its surface. Depending upon the type of carpet and method of installation, the moisture emission rate greatly influences the long-term success of an installation. The use of a properly installed, uncompromised, approved moisture membrane is essential in preventing moisture migration into and through a concrete slab. (Ref. ASTM F 710)**

### 8.1.1 Moisture Mitigation Systems

Concrete that has been treated with a moisture mitigation system will render the substrate non-porous. Before installation, a bond test is recommended. If the bond test fails, the substrate must be adequately prepared to accept adhesive.

## 8.2 Wood

Wood substrates are required to be structurally sound, flat, dry and securely anchored. Substrates, such as plywood, hardwood, particleboard, oriented strand board, or other materials, are required to be flooring grade (APA approved) and installed according to manufacturer specifications. Irregularities, imperfections and joints are required to be properly patched and prepared. The use of a primer on the substrate will improve bond strength of the patch.

### 8.2.1 Treated Wood

Wood that is chemically treated to alter properties relating to outdoor exposure or flame resistance is not a suitable substrate for direct glue-down applications. Floor covering adhesives would be subject to chemical degradation when applied to these surfaces.

### 8.3 Metal

It is required that metal floors create a smooth, even plane, and be free of grease, oil, soil and rust.

### 8.4 Raised Access Flooring

It is required that raised access flooring be structurally sound, flat and properly secured. For carpet tile installation, tile seams should be offset from access panel seams unless otherwise specified.

### 8.5 Resilient

Installing carpet over resilient flooring may be acceptable as long as the resilient flooring is securely bonded to the substrate and all waxes, sealers, floor finishes and other foreign materials have been removed. It is not recommended to install over floating, perimeter bonded or cushion-backed sheet goods.

**NOTE: Some sheet vinyl, resilient tile and cut-back asphalt-based adhesive may contain asbestos and/or crystalline silica. Recommended work practices prohibit sanding, dry scraping, bead-blasting or mechanically pulverizing resilient flooring, backing or lining felt. Do not use powered devices that create asbestos dust when removing “cut-back” or asphalt-based adhesives. Removal procedures must comply with federal, state and local government agency regulations covering the removal and disposal of asbestos-containing materials (ACM).**

### 8.6 Carpet over Carpet

Refer to carpet manufacturer for guidance before installation.

### 8.7 Radiant Heat Floors

Radiant-heated floors require special consideration in the selection of carpet, carpet cushion, installation methods and adhesive.

Unless absolutely certain about the location and depth of heating components, use adhesive to attach tack strip and transitions.

The maximum surface temperature of radiant-heated substrates should not exceed 85°F/29°C.

Refer to the [Radiant Panel Association](#) for additional information.

## **8.8 Terrazzo, Ceramic, Marble, Slate and Other Nonporous Surfaces**

Remove surface finishes and abrade flooring surfaces to ensure adhesion. Grout lines must be filled and flush with flooring material surface. Ceramic or other surfaces may require the use of a primer to ensure proper adhesion. Slate and brick surfaces may be too rough and uneven for most installations and may require the use of a self-leveler or smoothing before installing carpet. Attention must be given to the “open time” requirements of the adhesive manufacturer when adhering carpet to these surfaces.

## **8.9 Asphalt**

For approved flooring materials, it is required that asphalt surfaces be clean, dry, free from excessive oil and grease, and in good condition. Cure new asphalt for at least 90 days, or longer, depending upon weather conditions. Follow adhesive manufacturer’s requirements.

## **8.10 Painted Surfaces**

**NOTE: Lacking documented evidence to the contrary, e.g., current testing, assume that all paints contain lead and treat them in the manner prescribed by existing lead abatement regulations.**

Painted surfaces may be suitable for adhesive application; however, bond tests are recommended. Glossy surfaces must be abraded prior to installation. Contact the adhesive manufacturer for requirements.

## **8.11 Primers**

Using primers on floor surfaces generally is not required except for sanded wood sheet products and dusty, porous or acoustical concrete surfaces. Primers are not designed to reduce moisture vapor emissions and should not be used for that purpose. They should be compatible with adhesives, which can only be applied after the primer is cured. Where lightweight or acoustical concrete substrate is present, refer to manufacturer requirements for the proper installation procedure to use before the carpet is installed.

**NOTE: Substrate primers are recommended by some manufacturers for specific carpet installations to enhance adhesion.**

## **8.12 Chemical Adhesive Removers and Abatement Chemicals**

These products are not recommended for use on a substrate that will receive a floor covering.



### 8.13 Sweeping Compounds

Do not use sweeping compounds prior to adhesive application. The residue from these compounds interferes with adhesive bonding. Be sure to vacuum dusty areas instead. Vacuum cleaners are required to have a properly functioning filter per OSHA and/or EPA requirements.

### 9.0 Product Acclimation

It is recommended that carpet and installation materials be allowed to acclimate in the installation area for a minimum of 24 hours at a temperature of 65-95°F (18 -35°C). Carpet must be adequately protected from soil, dust, moisture and other contaminants. Follow manufacturer's instructions for acclimation.

### Carpet Tile

#### 10.0 Carpet Tile Installation

Due to the variation in tile size, shape, backing and installation methods (monolithic, ashlar, quarter turn, etc.) follow the carpet manufacturer's recommendations.

##### 10.1 Layout

Refer to [Section 5.0](#). To ensure straight-square installations, apply at least two perpendicular chalk lines onto the substrate (at a 90 degree angle to each other). These chalk lines should extend the entire length and width of the area to be covered. A laser line can be also utilized for this purpose. The location and intersection point of the chalk lines should be determined to achieve the design intent and reduce waste.

**NOTE: The intersection point mentioned above may or may not be in the center of a room in order to achieve the design intent.**

##### 10.2 Adhesive Application

Generally, a thin film of pressure-sensitive adhesive is applied and allowed to completely dry. The design of the adhesive is to prevent lateral movement of carpet tiles and for easy removal/replacement. Due to varying carpet tile backing, adhesive recommendations will differ. Follow manufacturer's recommendations.

**NOTE: In order to prevent adhesion issues or contamination, old adhesive residue must be removed and encapsulated prior to application of new adhesive.**

### 10.3 Tile Joints

Tile in the completed installation should be tight but not compressed. To insure proper spacing when installing carpet tile, measure the distance covered by 10 tiles installed on the floor with no visible gaps, peaks or overlaps. The measurement should be equal to 10 times the tile size +/- 1/4" unless otherwise stated in the manufacturer specifications. This measurement is an indication of correct placement of tiles to prevent compression or gapping between tiles. Take care not to trap yarn between tiles.

### 10.4 Rolling

Refer to manufacturer recommendation for roller weight. Rolling, if required, should be performed to press the tile into the adhesive.

### 10.5 Pre-applied Adhesive Systems (“peel-and-stick”)

Pressure sensitive adhesives sometimes are applied to attached-cushion backings during manufacturing. Backings of this type have special floor preparation requirements. Consult the carpet manufacturer for recommended installation procedures and the use of primers, if needed.

## 11.0 Post Installation

Refer to [Section 13.7](#)

## Broadloom Carpet

### 12.0 Carpet Seaming

All seams must be properly prepared in strict compliance with carpet manufacturer recommendations.

#### 12.1 Trimming

Carpet seams must be trimmed using tools and techniques best suited for the carpet style (e.g., loop-pile, cut-pile, cut-and-loop pile). Refer to the Tools and Materials table in the appendix of this standard. Trim edges far enough into the material to maintain the structural integrity of the carpet and to seam without gaps or overlaps.

**NOTE: Although “row-cutting” both edges is preferred, other trimming techniques may be more suitable on some carpet. Many carpets do not lend themselves to all methods of cutting. Trimming too far into patterned carpet will compromise pattern match. Contact carpet manufacturers for specific seaming methods.**

## 12.2 Sealing Edges/Seams

All seams must be sealed unless otherwise specified by the manufacturer. Regardless of installation method, most carpet requires an edge protective material be introduced between the edges to be joined. This material can be a liquid or thermoplastic and can be applied using various procedures and techniques.

### 12.2.1 Edge Sealing

For carpet backings that require edge sealing, apply an appropriate seam adhesive covering the thickness of the primary and secondary backing without contaminating face yarns on both edges of the seam. This ensures that all edges trimmed for seaming are protected from edge ravel. Allow seam adhesive to dry before proceeding with the installation to prevent transfer to the face yarn.

### 12.2.2 Seam Sealing (Direct Glue Down Only)

Apply a bead of seam adhesive to the cut edge of one side only in sufficient quantity to seal both trimmed edges. Ensure the bead thickness is sufficient to cover the primary and secondary backing without contaminating face yarns (See Figure 1). In order to bond the seam edges together, join the edges while the seam adhesive is still transferrable.

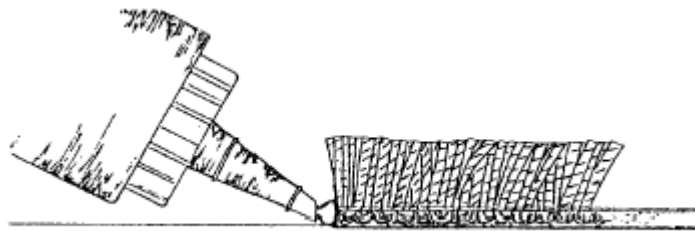

Figure 1

## 12.3 Seaming Methods

The seaming method depends upon carpet construction and backing type. Always follow manufacturer recommendations for seaming. Seaming methods include:

- hot-melt tape
- hand sewing

### 12.3.1 Hot Melt Seaming

A seaming tape pre-coated with a thermoplastic adhesive is centered beneath the seam. Tape is heated by a seaming device which melts the adhesive, laminating the carpet backing to the tape. Seams should be made over a hard, flat surface (i.e. seaming board). A carpet seam roller is recommended to achieve proper penetration of adhesive into the carpet backing from the seaming tape.

**NOTE:**

- **Premium grade tape with high tensile strength, sufficient adhesive on the woven scrim and a minimum adhesive width of 2 ¾ inches is recommended.**
- **Rollers with star or spike design are not recommended for use on hot melt seams, especially, cut or cut-loop constructions.**

When using a seaming iron, a grooved iron is recommended for better penetration of the adhesive. Proper iron temperature is essential to avoid secondary backing distortion. Temperature settings will vary according to iron and tape manufacturers. **Always run the iron in the direction of the pile. A heat shield is required.**

A metal surface should not be used to weight the seam behind the seaming device, as metal traps the heat and moisture. **Wood or non-heat conducting material should be used for this purpose.**

Provide adequate ventilation to dissipate any fumes from the seaming process.

### 12.3.2 Hand Sewing

Hand sewing shall be overcast stitches placed not more than 1/2 inch (13 mm) apart and no less than 1/2 inch from the edge of the carpet. It is recommended that a latex coating and tape be applied over the stitching.

## 12.4 Proper Seam Characteristics

With any seaming method, a properly constructed seam:

- has cleanly trimmed edges properly secured with edge/seam sealer
- has tightly abutted edges without gaps or overlaps
- maintains reasonable pattern match where applicable
- **will not be invisible**

## 13.0 Direct Glue Down

### 13.1 Layout

Refer to [Section 5.0](#). Lay out the carpet according to the seaming diagram. Where applicable, allow for pattern repeat. Dry lay and align all carpet breadths/widths to their proper position; and then trim seams.

### 13.2 Floor Adhesive Application

#### 13.2.1 Trowel Selection

Select the appropriate adhesive and trowel notch configuration recommended by the carpet manufacturer and/or adhesive supplier, or refer to the general minimum guidelines in [Table II](#).

#### 13.2.2 Adhesive Application

Spread floor adhesive uniformly over the substrate with an appropriate trowel, leaving ridges of sufficient height to achieve full and complete coverage of both the substrate and carpet backing. Trowel notches wear down during use. Replace trowel as necessary to maintain proper spread rate. After sufficient open time, press carpet into the adhesive and roll with an appropriate roller as specified in [Section 10.4](#).

**NOTE: Bond failure most often is caused by:**

- **inadequate adhesive application from incorrect trowel notch size and/or trowel notch configuration**
- **wear or improper trowel angle during application**
- **improper type and grade of adhesive**
- **incorrect open time and/or working times**
- **bond breakers or substrate contaminants such as, but not limited to, residual curing and parting compounds**
- **pH and moisture-related problems**
- **lack of protection**
- **premature traffic or cleaning before adhesives have adequately cured**
- **lack of protection, Refer to [Section 13.7.2](#)**

#### 13.2.3 Open/Tack Time

Appropriate open time varies depending upon environmental conditions, substrate porosity, backing system and adhesive type. Refer to the adhesive and/or carpet manufacturer for requirements regarding open/tack time.

#### **13.2.4 Working Time**

Working time (also referred to as slip time) is the length of time after covering the adhesive with carpet to make adjustments or manipulate the carpet without negatively impacting the permanent bond.

#### **13.3 Alternative Adhesive Systems**

Alternative field-applied systems, such as spray adhesive or roll-adhesive films, are available. Refer to carpet manufacturer information whether an adhesive system is acceptable.

#### **13.4 Seam Sealing**

All seams must be sealed unless otherwise specified by the manufacturer. Refer to [Section 12.2.2](#)

#### **13.5 Rolling**

After the required amount of adhesive has been applied to the floor and the prescribed open time has been allowed, the carpet is carefully placed into the adhesive. To insure an adequate bond, it is then required that the carpet be uniformly pressed into the adhesive using a roller designed for this purpose. Rolling should be performed with the lightest roller that will cause the adhesive ridge pattern to transfer to the back of the carpet while still leaving the adhesive bonded to the floor. Do not exceed 75 lbs. unless specifically directed by the manufacturer. Roll the carpet in both length and width directions.

**NOTE: In some circumstances, re-rolling is required as well as the placement of weights in problematic areas.**

#### **13.6 Finishing at Wall Line**

Finish the installation along the wall line leaving a net, smooth, neat, and secure fit.

#### **13.7 Post Installation**

##### **13.7.1 Curing Adhesives**

It is recommended that traffic over field-applied adhesive installations be restricted to installation personnel only for a minimum of 24-48 hours to allow adhesives to cure properly. Premature traffic will cause installation failure. Restrict carpet exposure to water from cleaning or other sources for a minimum of 30 days.

### 13.7.2 Materials for Protection

It is recommended that carpet installation be the last trade on any job site. However, if it is required to protect the finished floor covering from soil or paint, or if additional work is required to be done after the installation, the carpet should be covered with a non-staining, breathable building material paper. Protect the installation from rolling traffic by using sheets of hardboard or plywood in potentially affected areas.

**NOTE: Self-adhering plastic films may leave residues that result in rapid soiling after removal. Do not place plastic sheeting over any carpet installation because it may present a slip hazard. Most importantly, plastic coverings will trap moisture, retard adhesive curing and may promote mold growth.**

### 13.7.3 Maintain Temperature

Do not allow the temperature of carpeted areas to fall below 50° F (10° C), regardless of the age of the installation.

## 14.0 Double Glue Down

### 14.1 Cushion Layout

Refer to manufacturer's installation instructions. Install cushion in the longest continuous lengths possible with consideration to traffic patterns and carpet seam placement. It is required that cushion seams be at a right angle (90°) to carpet seams or offset at least 6 inches (150 mm). Butt cushion seams net without compression, leaving no gaps. Do not tape or staple cushion seams for double glue down installations.

**NOTE: Cushions should be specifically designed for double glue application and should not exceed 3/8 of an inch in thickness.**

### 14.2 Layout

Refer to [Section 5.0](#). Where applicable, allow for pattern repeat. Dry lay and align all carpet breadths/widths to their proper position; and then trim seams. Take care to avoid cutting into cushion under seams.

### 14.3 Adhesives and Trowel Notch Sizes

When applying cushion to substrate and carpet to cushion, select the appropriate adhesive and trowel notch size recommended by the carpet, cushion and adhesive manufacturer. If recommendations are not available, refer to the general minimum guidelines in [Table II](#).

#### 14.4 Cushion to Substrate Installation

Spread adhesive uniformly over the substrate with the specified trowel or other application procedure. After sufficient open time, the cushion is to be installed into the adhesive in a manner that minimizes air pockets. Proper open time is critical for a successful installation.

**NOTE: For cushion to substrate, adhesives, application methods and spread rates are different from carpet to cushion installation methods. Refer to manufacturer's installation instructions.**

#### 14.5 Carpet to Cushion Installation

When applying carpet to cushion, select the appropriate adhesive and trowel notch size recommended by the carpet, cushion and adhesive manufacturer. If recommendations are not available, refer to the general minimum guidelines in Table II. Spread adhesive uniformly over the cushion with the specified trowel or other application procedure.

After sufficient open time, the carpet is to be placed into the adhesive and rolled with the appropriate roller. ***Proper open time is critical for a successful installation.***

**NOTE: When spreading adhesive over cushion, excessive trowel pressure reduces effective adhesive coverage rate.**

#### 14.6 Edge Sealing

All seams must be sealed unless otherwise specified by the manufacturer. Refer to [Section 12.2.1](#).

#### 14.7 Seam Cutting

Although “row-cutting” both edges is preferred, other trimming techniques may be more suitable on some carpet. Many carpets do not lend themselves to all methods of cutting. Contact carpet manufacturers for specific seam cutting methods.

#### 14.8 Seaming

Hot melt seaming is required for double glue installations unless otherwise specified by the manufacturer. **Do not use silicone coated seaming tape.** Refer to [Section 12.3.1](#).

#### 14.9 Rolling

Rolling carpet to cushion is required. Refer to [Section 13.5](#).



## **14.10 Post Installation**

Protection is required for double glue installations. Refer to [Section 13.7](#).

## **15.0 Attached Cushion Install**

### **15.1 Carpet Layout**

Refer to [Section 5.0](#).

### **15.2 Floor-Applied Adhesive Installations**

Use the carpet adhesive and seam adhesive recommended by the carpet or adhesive manufacturer.

#### **15.2.1 Trowel Notch Size**

Refer to the general minimum guidelines in [Table II](#).

#### **15.2.2 Open Time**

Refer to [Section 13.2.3](#).

### **15.3 Installation Procedures**

Cut seam edges with appropriate tools based on carpet manufacturer recommendations. Trim into material to eliminate possible height variation at the seam. In the case of woven goods, carefully refer to the manufacturer's recommendation for that specific style. Seal cut edges at seams with proper seam adhesive applied as recommended by the carpet or adhesive manufacturer. Roll installed carpet according to manufacturer recommendations.

### 15.3.1 Seam Sealing (Attached Cushion Products)

Apply a bead of seam adhesive to the cut edge of one side only in sufficient quantity to seal both trimmed edges. Ensure the bead thickness is sufficient to cover the primary and secondary backing (above the cushion) without contaminating face yarns (See Figure 2). In order to bond the seam edges together, join the edges while the seam adhesive is still transferrable.

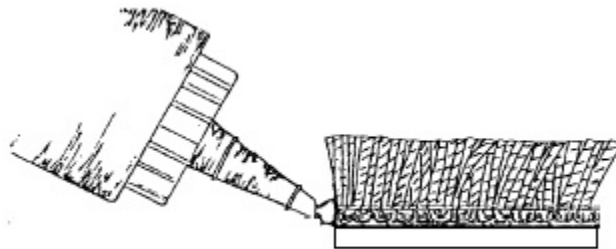

Figure 2

### 15.4 Pre-applied Adhesive Systems (“peel-and-stick”)

Pressure sensitive adhesives sometimes are applied to attached-cushion backings during manufacturing. Backings of this type have special floor preparation requirements. Consult the carpet manufacturer for recommended installation procedures and the use of primers, if needed.

## 16.0 Stretch-in Installation

This method involves installing carpet under tension over a separate cushion, using tack-strips fastened at all walls and other vertical abutments.

### 16.1 Tack-strip

Architectural strips, 1 3/4” inches in width (50mm) with 3 rows of pins, or 2 conventional strips with 2 rows of pins each, are required to provide secure attachment of the carpet and additional shear strength. To prevent possible injury to building occupants, it is required that the pins on tack-strips not protrude through the carpet being installed.

Additional tack-strip installation specifications include:

- Securely fasten tack-strips to maintain the tension provided by power stretching. Nailed or stapled tack-strips are required to have a minimum of 2 fasteners per piece.
- Place tack-strips with the pins angled toward the vertical abutment.
- The gully, or distance between the tack-strips and vertical abutments, is required to be slightly less than the thickness of the carpet but not exceed 3/8 inch (9 mm).
- Avoid installing tack-strips across door openings and/or sills.

- Cut tack-strips to follow the contour of door casings and other irregularly shaped abutments.
- Do not staple carpet to tack-strips.
- On radiant-heated floors, use manufacturer's approved adhesive to secure tack-strips. Do not use nails or screws to prevent damage to heating system.

## **16.2 Separate Cushion Selection**

It is required that the cushion conform to carpet manufacturer recommendations for the specific product being installed. Failure to follow these recommendations for cushion may void manufacturer warranties. These recommendations may differ, depending on the style and construction of specific carpet. **Cushion thickness for commercial carpet installations should not exceed 3/8 inch (10 mm).**

Install separate carpet cushion in the longest continuous lengths possible, with cushion seams placed at right angles to carpet seams, or offset at least 6 inches (150 mm) to one side. Trim cushion flush with the inside contour of the tack strip and securely fasten to the substrate using staples or nonflammable cushion adhesive at all seams and around the perimeter of each room. With the exception of fiber cushions, secure seams with appropriate vinyl-coated cloth cushion tape per the carpet cushion manufacturer's recommendations.

## **16.3 Seaming**

The seaming method depends upon carpet construction and backing type. Refer to [Section 12](#).

## **16.4 Power Stretching**

Power-stretch carpet following the 7 step procedure described in Figure 3 (see next page).

**Figure 3:** Stretch Diagram for Tufted Carpet  
In the absence of carpet manufacturer stretch recommendations, use this diagram.

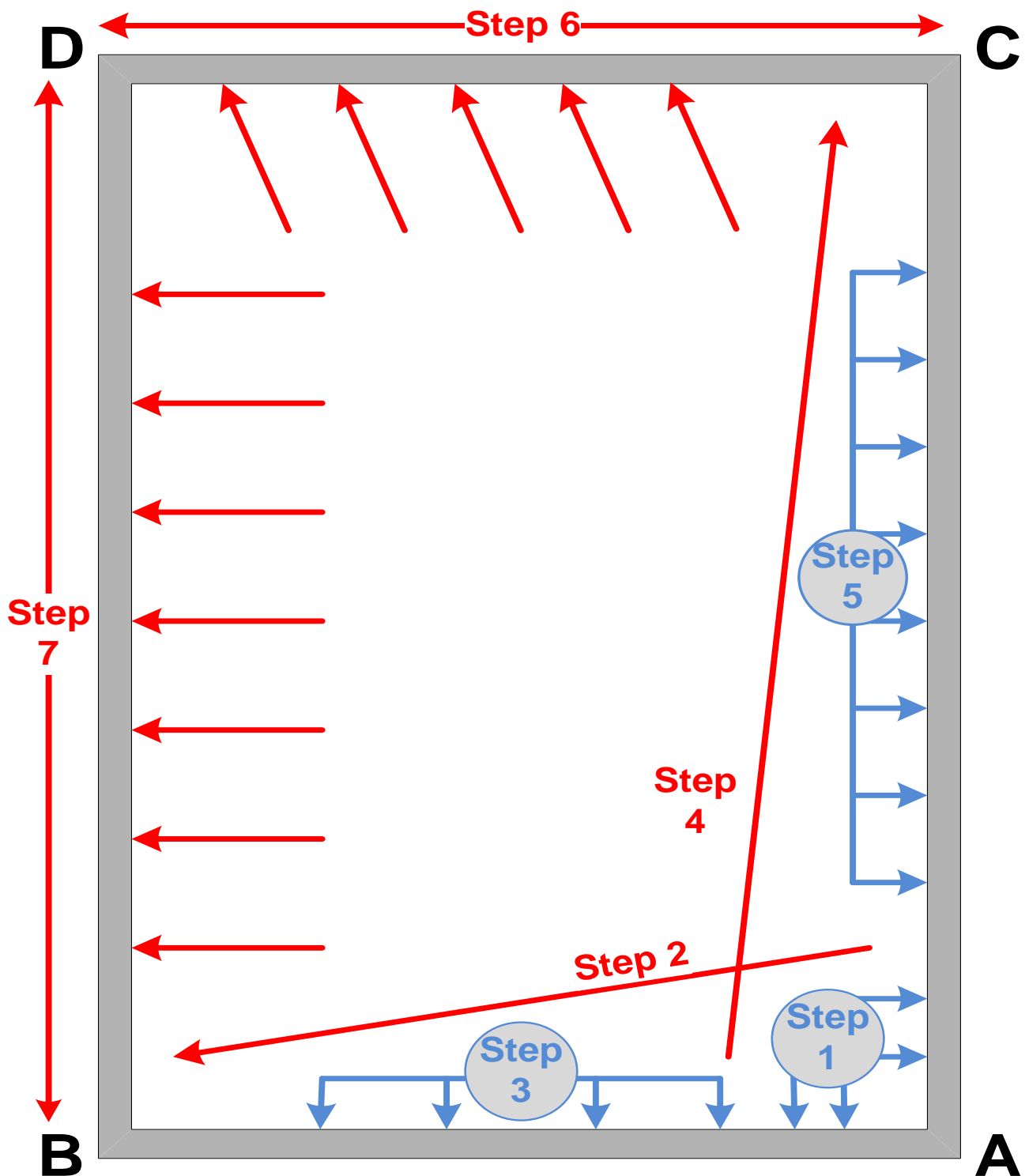

**For Woven Carpets, contact manufacturer for stretch-in requirements.**

**NOTE: Size and shape of the room will determine corner designation. Red arrows denote use of a power stretcher and blue arrows denote use of a knee kicker.**

**Step 1: Hook onto tack strip approx. 3 ft. in both directions along corner A.**

**Step 2: Power stretch at approx. 15° angle from wall AC and hook onto tack strips at corner B.**

**Step 3: Hook & secure onto tack strip with knee kicker along wall from A to B.**

**Step 4: Power stretch at approx. 15° angle from wall AB and hook onto tack strip at corner C.**

**Step 5: Hook & secure onto tack strip with knee kicker along wall from A to C.**

**Step 6: Power stretch at approx. 15° angle from wall AB and hook along wall from C to D.**

**Step 7: Power stretch from wall AC and hook along wall from B to D.**

**The use of a Power Stretcher is *MANDATORY*.** Devices used as a substitute for, or an attachment to such devices that penetrate through the carpet backing may cause injury, damage carpet or substrates, or result in inadequate stretch. Such devices are not acceptable.

**Power stretcher** – This tool should have all of the following:

- Based on the carpet construction, the proper head should be selected for the power stretcher :
  - pins – recommended for cut pile
  - cotton head – recommended for loop construction
- Ability to lock the stretch in place.
- Adjustable metal tubes ending in a padded tail block/plate.

**NOTE: Failure to power stretch may result in:**

- **wrinkling and buckling**
- **damage to the carpet**
- **delamination of secondary backing**

## **16.5 Amount of Stretch**

Due to the difference in carpet backing types, it is required that manufacturer instructions for carpet stretch be followed. In the absence of specific instructions, tufted carpet with synthetic backing should be stretched a minimum of 1% in length and width. Patterned carpet may require additional stretch to obtain pattern match.

## 16.6 Finishing at Wall

Finish the installation along the wall, leaving a smooth, neat and secure transition. Trim carpet without damaging baseboards or moldings, leaving sufficient material for backing to be securely tucked into the gully without protruding face or backing yarns.

## 16.7 Transition Molding

Refer to [Section 5.3](#)

## 17.0 Carpet on Stairs

### 17.1 Preparation

It is required that the stair tread, riser and stair nose should be clean, dry and structurally sound. The stair nose return should be rounded  $\frac{3}{4}$  to 1 inch (19 to 25 mm) to prevent sharp stair edges from cutting carpet and/or cushion, and to provide proper carpet contact for adhesive installations. When carpet is installed over a separate cushion, extend the cushion over the stair nose.

### 17.2 Stretch-in Installation

Tack strip is to be installed on each tread. It is required that pins on the tread point toward the riser. On a waterfall-type stair installation, tack strip is to be installed on risers also. Pins on risers point down to the tread. It is required that the gully between strips be slightly less than double the carpet thickness. Where a turned finish is desired, tack strip and cushion are about  $1\frac{1}{2}$  inches (38 mm) less than the carpet width, to allow for a “turn-and tack” on each side of the stairs. Some stairs require tack strip on the sides to maintain the proper tension. When using a cap-and-band or contoured technique, tack strip is not used on riser.

**NOTE: When staples are used in upholstering carpet on stairs, take care to separate pile yarns to avoid trapping yarns, resulting in visible distortion. If the edges are exposed, they must be edge sealed. Upholstery work needs to have no raw edges exposed. Any seams or joints must be sealed. Carpet seams need to be split in the direction of the balusters/spindles.**

### 17.3 Glue-down Installation

Install carpet on stair treads and risers using recommended adhesive. Stairs without a return (nose) can be installed as one piece over the tread and riser. It is required that on stairs with a return, carpet be cut and installed with the tread and riser being separate pieces.

## 17.4 Carpet Direction

It is recommended that machine direction of the carpet be installed in the length direction of the stairs.

**NOTE: Most manufacturers recommend carpet pile direction run down the stairs.**

## 18.0 Patterned Carpet Installations

### 18.1 Uninstalled Patterned Carpet

Carpet is a textile fabric subject to processing variations in the four pattern conditions: bow, skew/bias, elongation variation and trueness of edge. Measurement of these four conditions is performed on an uninstalled breadth/width of carpet. Individual manufacturers have tolerances to which their patterned products are required to conform. There are no industry standards for carpet pattern variation.

### 18.2 Manufacturing Tolerances

Most manufacturers provide established tolerances and specific installation instructions for their patterned goods.

Factors affecting pattern match on the job site include, but are not limited to:

- method of installation
- condition and levelness of the floor
- type of carpet backing system selected.

Alignment of patterned carpet typically requires the use of mechanical stretching devices (i.e. power stretcher, mini stretcher, etc.).

### 18.3 Seaming Diagram

It is required that the seaming diagram reflect the desired pattern direction. Refer to [Section 5.0](#).

#### 18.3.1 Patterned Carpet in Corridors

It is recommended that carpet with width-wise linear patterns not be installed breadth-to-breadth along the length of a corridor to avoid inconsistent alignment of pattern.

## 18.4 Pattern Sequence/Roll Sequence

Sequencing information may be available from the carpet manufacturer. In the absence of sequencing information from the carpet manufacturer, sequence carpet cuts working from the longest measured repeat gradually down to the shortest repeat within the dye lot.

**NOTE: Patterned carpet requires additional material for proper pattern matching.**

## 18.5 Pattern Adjustment

Pattern adjustment during installation should be anticipated.

## 18.6 Pattern Alignment

Match the pattern at the midpoint of the seam's length. Work from the seam's midpoint to the seam ends.

Bring the pattern into register using appropriate tools that might include (refer to [Table I](#)):

- power stretcher
- knee kicker
- dead man
- “dry” lines
- stay nails
- double-headed mini-stretcher (“crab stretcher”)

**NOTE: For patterned carpet, exercise care to ensure pattern alignment along walls. The use of mechanical stretching devices, stay-nails and a “dead man” may be necessary to achieve pattern match at seams and alignment along walls.**



## Appendices

### Definition of Terms

**Adhesive** – A substance that dries to a film capable of holding materials together by surface attachment. Applying adhesive to the floor normally is accomplished with a trowel, airless spray, or roller.

**Adhesive transfer** – It is the degree of coverage and penetration of the applied adhesive into the back of carpet while still maintaining full coverage of the floor. The degree of coverage may be influenced by adhesive type, method of installation, open assembly time and other factors.

**Alkali** – Having a pH greater than 7.

**Attached cushion** – Cushion material permanently bonded to the back of carpet by the manufacturer.

**Baseboard** – A board skirting the lower edge of a wall, covering the junction of the wall and the floor.

**Broadloom** – Carpet manufactured in a roll format.

**Calcium chloride test** – ASTM F1869 test method that is used to obtain measurements of moisture vapor emission rates over concrete substrates.

**Carpet cushion** – Material placed under carpet to provide resiliency, support, insulation qualities and noise reduction; also referred to as carpet lining, padding, or underlay, although “carpet cushion” is the preferred industry term.

**Carpet Tiles** – Various shapes and sizes of carpet precut during manufacturing with applied backings.

**Conditioning** – The process of allowing the substrate, carpet, cushion and sundries to relax or acclimate to the proper environment into which it is to be installed as described in the text.

**Curing Compounds** – Chemicals used to accelerate the curing time of concrete. [These can be adhesive bond breakers]

**Dead man** – A device used in carpet installation to provide a point of resistance for facilitating stretching procedures. Construction is a board with strips of tack strip attached to the bottom side.

**Direct glue down** – This is an installation method where carpet is adhered to the substrate using the proper adhesive.

**Double glue down** – This is an installation method where carpet cushion is first adhered to the substrate, and the carpet is then adhered to the cushion using the proper adhesives.

**Double-headed mini-stretcher (crab stretcher)** – Hand device used for aligning patterns where a power stretcher cannot be used; also used for removing fullness at seams and closing gaps at seams.

**Dry line** – This is a length of line or cord, which is stretched slightly above the carpet, but not touching the carpet, and used as a visual reference in pattern alignment. Lasers also may be used in this capacity.

**Edge Ravel** – A condition of yarn loss in installed carpet when the edges begin to fray.

**Gully** – The distance between the tack strip and the wall. A gully should always be slightly less than the thickness of the carpet and not exceeding 3/8 inch.

**HVAC** – Acronym for “heating, ventilating, and air conditioning” referring to indoor climate control systems.

**High Moisture Carpet Adhesive** – This is an adhesive that will work in a high moisture environment, however it does not act as a moisture barrier. See adhesive manufacturer for warranty information.

**Knee-kicker** – This is an installation tool designed to position carpet, hook and secure carpet onto the tack strip and also perform stair installations. [NOTE: A knee kicker is not for stretching carpet.]

**Open time** – The earliest time interval between the spreading of adhesive on a substrate and the placement of a floor covering material into the adhesive for bonding.

**Patching** – Floor preparation process of filling holes, cracks, and imperfections, etc., in a floor substrate prior to installation of carpet

**Pattern bow** – This is a distortion visible as wavy or crooked pattern lines when viewed across carpet width.

**Pattern elongation** – This is a variation of cumulative pattern measurements from one breadth/width to the next. It is often referred to as “pattern run-off” or “Length Pattern Repeat (LPR)”. [Sequencing of cuts minimizes effects.]

**Pattern skew** – This is a distortion visible when the pattern on one side is slightly ahead of the pattern on the other side. Skew, or bias, describes pattern squareness.

**pH** – A value representing the concentration of hydrogen ions in gram equivalents per liter used to indicate the acidity or alkalinity (base) of a substance on a scale from 0 to 14 with 7 representing neutrality, numbers less than 7 increasing acidity, and numbers greater than 7 increasing alkalinity. [Use distilled water for laboratory and field testing for pH.]

**Plasticizer** – A substance incorporated into polyvinyl chloride polymer or other polymers to increase flexibility and workability.

**Power stretcher** – A carpet tool used to stretch carpet. Consists of a pinned plate or cotton head that grips the carpet, tubular extensions, a padded end used to brace against an opposing wall or other structure (dead man), and a lever system that multiplies the installer’s applied stretching force.

**Primer** – A preparatory coating placed on a substrate or material to promote adhesion and neutralize pH.

**Riser** – The upright part of a step between two stair treads.

**Sealer** – A product used to reduce the porosity of the substrate.

**Seam** – The joints or interface of two pieces of carpet by the use of various securing techniques.

**Seam adhesive** – A specifically formulated adhesive for securing and protecting cut edges of carpet to be seamed.

**Seaming Device** – Tools designed to melt seaming tape.

**Seam peaking** – The slight elevation of the taped seams which is a (usually renders the seam more visible) result from power stretching of the carpet. For additional information, refer to CRI Technical Bulletin “[Peaking Seams in Stretch-In Carpet Installations](#)”.

**Seam sealing/Edge sealing** – Common term used to describe the application of seam adhesive to secure and protect cut edges of carpet to be seamed from edge raveling and delamination.

**Seaming tape** – tape used for joining two sections of carpet. [“Hot melt” tape is pre-coated with a thermoplastic adhesive. Adhesives may be applied separately to other types of seaming tapes.]

**Secondary backing** – Woven or non-woven fabric reinforcement laminated to the back of tufted carpet, usually with an adhesive, to enhance dimensional stability, strength, stretch resistance, and ease of handling.

**Selvage (selvedge)** – The lengthwise, factory-finished edge portion of a carpet.

**Shoe molding** – Wood or plastic strip with one corner edge rounded slightly. Used to conceal the floor/wall line junction or between larger moldings and floors.

**Stair nose** – leading edge of a stair tread. For carpet installation, it is required that this edge be rounded.

**Stay nailing** – A technique of temporarily fastening carpet to the floor using nails to prevent movement until permanent fastening with tack strips, adhesives, or other means is possible. This technique is commonly used to align patterned carpet.

**Stretch-in** – Installation method whereby carpet is placed over separate carpet cushion and is secured in place, under tension, using a power stretcher (mechanical stretching device).

**Substrate** – A general term that means any surface below another surface, but which in the floor covering industry, most often refers to the stabilizing layer of material directly beneath the finish flooring.

**Tack strip** – Wood strip fastened to the floor near the walls of a room, containing either two or three rows of pins angled toward the walls on which the carpet is stretched and secured in a stretch-in installation. (Also referred to as “tackless strip”)

**Telegraphing** – The gradual appearance of irregularities, imperfections, or patterns from a substrate onto the surface of the carpet which can include seaming tape.

**Threshold** – The raised material beneath a door. This is also known as a “door sill” or “saddle.”

**Transition molding** – A wooden, metal, vinyl, or plastic strips to cover raw edges of carpet at doorways or where carpet abuts another type of floor covering. There are two basic types: 1) Applied before – Shapes put in place before carpet is installed and carpet is fitted to them, commonly called “gripper bar”; 2) Applied after – Shapes put in place on top of installed carpet commonly called “flat bar.”

**Tread** – The horizontal part (walking surface) of a stair.

**Trowel** – Hand implement used for metering and spreading adhesive to the floor or other substrate.

**Trueness of edge/Bow in length** – It is generally measured as maximum deviation from a straight line, over a defined distance, between common pattern points along the machine direction of the carpet.

**Tufted carpet** – Carpet manufactured by the process of inserting pile yarns into a primary backing fabric through needles.

**Unitary carpet** – Carpet back-coated with a compound intended to increase physical properties normally without the addition of a secondary backing.

**Working time (may be referred to as slip time)** – It is the length of time available after covering the adhesive with carpet to make adjustments or manipulate the carpet.

**Woven carpet** – Carpet produced on a loom. The lengthwise (warp) yarns and widthwise (weft or filling) yarns are interlaced to form the fabric. Carpet weaves, such as Wilton, Axminster and velvet, are complex, often involving several sets of warp and fill yarns for the pile and backing.

## Table I – Tools & Materials

### Tools

#### **A. Tape Measure (Metal)**

1. 25 ft. (7.6 m)
2. 50 ft. (15.2 m)
3. 100 ft. (30.5 m)

#### **B. Straight Edge**

1. Rigid

#### **C. Chalk Line**

1. White Chalk
2. Red or Blue (Substrate Only)

#### **D. Knives and Cutters**

1. Carpet Knife
2. Utility Knife
3. Wall Trimmer
4. Carpet Shears
5. Nap Shears (Duck Bills)
6. Tin Shears
7. Tack Strip Cutter

#### **E. Hammers and Mallets**

1. 16 to 20 oz. Hammer
2. White Rubber Mallet

#### **F. Staplers / Tackers**

1. Electric Stapler
2. Hammer Tacker

#### **G. Screwdrivers**

1. Phillips
2. Standard

#### **H. Trowels**

1. See [Table II](#)

#### **I. Rollers**

- 1 35 lb (16 kg)
- 2 50 lb (23 kg)
- 3 75 lb (34 kg)

#### **J. Power Stretcher**

1. Junior
2. Senior
3. Carpet Spreader

#### **K. Positioning Tools**

1. Adjustable Knee Kicker
2. Double Headed Mini Stretcher

#### **L. Seaming**

1. Awl / Row Runner
2. Cushion Back Cutter
3. Loop Pile Cutter
4. Carpet Seam Roller (Flat and Paddle)
5. Wood / Non-Conductive Weight to follow Hot Melt Seaming Iron
6. Stay Nails

#### **M. Seaming Device**

1. Hot Melt Seaming Iron and Shield (3 inch or 6 inch)
2. RF (Radio Frequency) Seaming Unit

#### **N. Miscellaneous**

1. Base Shoe Lifter
2. Drive Down Bar
3. Stair Tool
4. Pliers
5. Extension Cord and Adapter
6. Hammer Drill / Mixing Paddle
7. Miter Box
8. Hacksaw
9. Door Pin Remover
10. First Aid Supplies
11. Carpenter Square
12. Pencil and Note Pad
13. Chalk Stick
14. Marking Pin
15. Thimble
16. Curved Needle and Thread
17. Vacuum Cleaner / Broom
18. Dry Lines
19. Knee Pads

## **Materials**

### **A. Metal and Vinyl Moldings**

1. Flat Metal
2. Cap Molding (T-track)
3. Stair Nosing
4. Accent Molding
5. Tap-Down (Gripper Bar or Flat)
6. Access Panel Molding
7. Z-Bar

### **B. Seaming Tape**

1. Hot Melt
2. Latex

### **C. Seam Sealer**

1. Liquid Seam Sealer
2. Thermoplastic sticks and applicator

### **D. Tack Strip**

1. See [Table III](#) for Various Widths

**Table II – Trowel Size Minimum Guidelines**

FLOOR COVERING/SUBSTRATE	APPLICATOR SIZE	APPROXIMATE SPREAD RATE feet <sup>2</sup> / gal.	APPROXIMATE SPREAD RATE yards <sup>2</sup> / gal.
Broadloom Carpet: rough back, woven, double stick carpet to cushion	1/8" x 1/8" x 1/8" U or Square notch (3.2mm x 3.2mm x 3.2mm)	50 – 90	6 – 10
	1/8" x 1/8" x 1/16" U notch (3.2mm x 3.2mm x 1.6mm)	45 – 75	5 – 8
Broadloom Carpet: Action Bac®, unitary back, jute	1/8" x 1/8" x 1/8" V notch (3.2mm x 3.2mm x 3.2mm)	90 – 110	10 – 12
	1/8" x 1/8" x 1/16" V notch (3.2mm x 3.2mm x 1.6mm)	70 – 90	8 – 10
Broadloom Carpet: smooth back, attached cushion, needle punched, cove base	3/32" x 3/32" x 3/32" V notch (2.4mm x 2.4mm x 2.4mm)	90 – 135	10 – 15
Vinyl back broadloom carpet, carpet pad to floor double stick, cork tile and underlay	1/16" x 1/16" x 1/16" Sq. notch (1.6mm x 1.6mm x 1.6mm)	160 – 180	18 – 20
Vinyl back broadloom carpet, carpet pad to floor double stick, cork tile and underlay	1/16" x 1/16" x 1/16" U notch (1.6mm x 1.6mm x 1.6mm)	160 – 180	18 – 20
Carpet tile	3/8" Nap Paint Roller (9.5mm)	350 – 400	35 – 45
	3/4" Nap Paint Roller (19.0mm)	270 - 360	30 - 40

**Note: Above dimensions are given as width x depth x spacing. Spread rates vary with texture and porosity of the substrate. Trowels should be held at a consistent 45-60° angle to apply adhesive. Examine notches regularly for wear.**

**Table III – Tack Strip**

**TYPES AND WIDTHS OF CARPET TACK STRIP AVAILABLE**

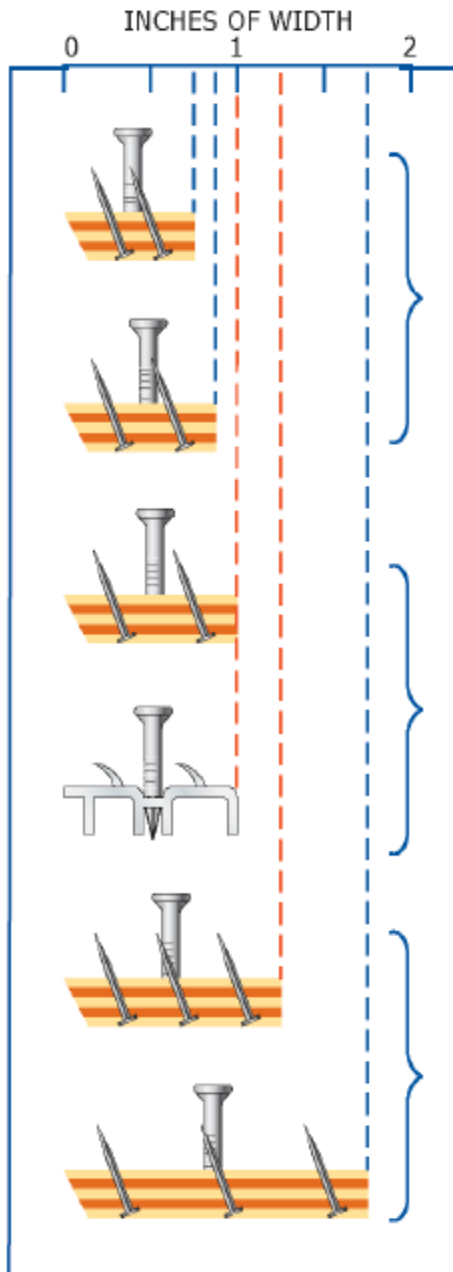

**Tack strip less than one inch (standard width) is not recommended for stretch-in carpet installations.**

Plywood tack strip widths do vary and the narrower widths cause additional problems for installers. Pre-nails and pins get closer to the wall as the width narrows.

**It is recommended to use one inch wide (standard width) tack strip for all carpet installations less than 30 ft. long.**

Pre-nails and front and back row of pins are moved farther from the wall for easier nail setting, extra strength and easier carpet hooking.

**Aluminum carpet strip is recommended for carpet installations where water or termites may cause damage to plywood tack strips.**

Will not rust, rot or be eaten by insects.

**Its is recommended to use tack strip with 3 rows of pins and at least 1 1/4 inches wide for carpet installations over 30 ft. long.**

Extra pins provide more strength. Wider plywood provides stronger platform for power stretching.



**Table IV – Adhesive Types / Definitions**

**Adhesives – Common Types Used in Carpet Installation**

**A. Carpet Floor Adhesives**

1. **Latex Adhesive:** Common name for adhesives used to install broadloom carpets, excluding those with vinyl backing, either directly to a substrate or over underlayment and cushion. Refer to carpet manufacturer for adhesive grade recommendation for specific backings and uses.
2. **Multi-purpose Adhesive:** A latex adhesive designated for use with varying carpet types as well as non-vinyl backed (mineral-felt backed) resilient sheet goods.
3. **Vinyl-Back Carpet Adhesive:** Adhesive specifically formulated for permanent installation of vinyl back carpet.
4. **Modular-Carpet Adhesive:** Pressure sensitive type adhesive for releasable installation of modular carpets. Note: Always consult manufacturer for proper type adhesive.
5. **Outdoor Carpet Adhesive:** Water resistant adhesive for installations of carpet designed for outdoor use. Refer to adhesive manufacturer for adhesive grade recommendation for specific backings.
6. **Polyurethane Carpet Adhesive:** For installing specific polyurethane backings. Refer to adhesive manufacturer.
7. **Contact Adhesive:** Used for bonding various carpet edge moldings to a substrate. It can be used for adhering carpet to difficult or irregular surfaces.

**B. Carpet Seaming Adhesives (Seam Sealer)**

1. **Vinyl-back Seam Adhesive:** Solvent-based (chemical weld) or solvent-free (mechanical bond).
2. **Latex Seam Adhesive:** For applying seaming tapes, reinforcing sewn seams, sealing trimmed edges prior to “hot melt” seaming, securing binding, etc.
3. **Hot Melt Seam Adhesive:** A thermoplastic adhesive used for adhesive or stretch-in applications.

**Table V – Dew Point**

**Ambient Air Temperature in Degrees Fahrenheit**

Relative Humidity	40°F	45°F	50°F	55°F	60°F	65°F	70°F	75°F	80°F	85°F	90°F
90%	37	42	46	52	57	62	67	72	77	81	87
85%	35	40	45	50	55	60	65	70	75	80	84
80%	34	39	44	49	54	59	63	68	73	78	82
75%	32	37	42	47	52	57	62	66	71	76	80
70%	31	35	40	45	50	55	60	64	68	74	78
65%	30	33	38	43	47	53	57	62	66	72	76
60%	27	32	36	40	45	50	55	60	64	69	73
55%	26	30	34	38	43	48	53	58	61	67	70
50%		28	32	36	40	45	50	55	59	64	67
45%		26	30	33	37	42	47	52	56	61	64
40%		21	27	32	35	40	43	49	52	58	61
35%			24	28	31	36	40	45	48	54	57
30%				25	28	32	36	41	44	50	52

SURFACE TEMPERATURE AT WHICH CONDENSATION OCCURS

**HOW TO USE THIS CHART:** If the air temperature is 80°F and the RH is 65%, the dew point is 66°F. No coating should be applied unless the surface temperature of the slab is 71°F or higher.

**DEW POINT:** Temperature at which moisture will condense on the surface of an object. No coatings should be applied unless surface of the concrete slab is a minimum of 5 degrees above this point. Ambient temperature must be maintained during curing, or can be falling, but never rising.

**RELATIVE HUMIDITY (RH):** The amount of water vapor in a mixture of air and water vapor. It is defined as the ratio of the partial pressure of water vapor in an air-water mixture to the saturated vapor pressure of water at a prescribed temperature.

**AMBIENT AIR TEMPERATURE:** The ambient temperature is a non-specific phrase used to describe the outside temperature. When taking the temperature with a thermometer, you are getting a general idea of the temperature of the surrounding air without taking into account the humidity or wind in the air.

## CRI Member Contact Information

<b>MANUFACTURER</b>	<b>WEBSITE</b>	<b>PHONE</b>
Advanced Adhesive Technologies	<a href="http://www.aatglue.com">www.aatglue.com</a>	800-228-4583
Atlas Carpet Mills	<a href="http://www.atlascarpetmills.com">www.atlascarpetmills.com</a>	800-372-6274
Beaulieu Group, LLC	<a href="http://www.beaulieu-usa.com">www.beaulieu-usa.com</a>	800-227-7211
Bentley Mills, Inc.	<a href="http://www.bentleymills.com">www.bentleymills.com</a>	800-423-4709
Bloomsburg Carpet Industries.Inc.	<a href="http://www.bloomsburgcarpet.com">www.bloomsburgcarpet.com</a>	800-233-8773
Constantine-Milliken	<a href="http://www.millikencarpets.com">www.millikencarpets.com</a>	800-277-8533
Daltonian Flooring, Inc.	<a href="http://www.daltonian.com">www.daltonian.com</a>	800-788-1408
The Dixie Group, Inc.	<a href="http://www.thedixiegroup.com">www.thedixiegroup.com</a>	866-606-7475
Engineered Floors, LLC	<a href="http://www.engineeredfloorsllc.com">www.engineeredfloorsllc.com</a>	706-625-4334
Godfrey Hirst USA	<a href="http://www.godfreyhirstusa.com">www.godfreyhirstusa.com</a>	800-480-7134
HB Fuller Construction, Inc.	<a href="http://www.hbfuller-cp.com">www.hbfuller-cp.com</a>	800-552-6225
Interface, Inc.	<a href="http://www.interface.com">www.interface.com</a>	800-336-0225
J+J Flooring Group	<a href="http://www.jjindustries.com">www.jjindustries.com</a>	800-241-4586
Mannington Mills, Inc.	<a href="http://www.mannington.com">www.mannington.com</a>	800-241-2262
Mapei Corporation / APAC	<a href="http://www.mapei.com">www.mapei.com</a>	800-426-2734
Masland Carpets & Rugs	<a href="http://www.maslandcarpets.com">www.maslandcarpets.com</a>	800-633-0468
Millennium Weavers, LLC	<a href="http://www.millenniumweavers.com">www.millenniumweavers.com</a>	406-383-6141
Milliken & Company	<a href="http://www.millikencarpets.com">www.millikencarpets.com</a>	800-241-4826
Modulyss	<a href="http://www.modulyss.com">www.modulyss.com</a>	+32 (0)52 45 72 11
Mohawk Industries, Inc.	<a href="http://www.mohawkind.com">www.mohawkind.com</a>	800-241-4494
Northwest Carpets	<a href="http://www.northwestcarpets.net">www.northwestcarpets.net</a>	800-367-2508
Roberts Capitol	<a href="http://www.qep.com">www.qep.com</a>	800-831-8381
Royal Adhesives & Sealants	<a href="http://www.royaladhesives.com">www.royaladhesives.com</a>	800-763-7272
Royalty Carpet Mills	<a href="http://www.royalcarpetmills.com">www.royalcarpetmills.com</a>	800-854-8331
Shaw Industries, Inc.	<a href="http://www.shawfloors.com">www.shawfloors.com</a>	800-441-7429
StarNet Worldwide Commercial Flooring Partnership	<a href="http://www.starnetflooring.com">www.starnetflooring.com</a>	800-787-6381
Tai Ping Carpets Americas, Inc.	<a href="http://www.taipingcarpets.com">www.taipingcarpets.com</a>	800-433-2440
Tandus Centiva, Inc.	<a href="http://www.tandus.com">www.tandus.com</a>	800-248-2878
Totally Enterprises, LLC	<a href="http://www.totallycarpet.com">www.totallycarpet.com</a>	888-882-1500
Woolshire Carpet Mills, Inc.	<a href="http://www.woolshire.com">www.woolshire.com</a>	800-799-6657
W.F. Taylor Co., Inc	<a href="http://www.wftaylor.com">www.wftaylor.com</a>	800-397-4583
W.W. Henry Company and Ardex	<a href="http://www.wwhenry.com">www.wwhenry.com</a>	800-232-4832
XL Brands	<a href="http://www.xlbrands.com">www.xlbrands.com</a>	800-367-4583